

# FROM STUDENT EXPERIMENTS TO MOON AND MARS

Emil Nathanson<sup>(1)</sup>, Christine Hill<sup>(2)</sup>, Andreas Fink<sup>(3)</sup>, Thorben Heinrichs<sup>(4)</sup>, Robert Schelling<sup>(5)</sup>,  
Juergen Schlutz<sup>(6)</sup>, Daniel Stoerk<sup>(7)</sup>, Johannes Wepler<sup>(8)</sup>

<sup>(1)</sup>University of Stuttgart, Wolfmardenstraße 46, 70563 Stuttgart, Germany, Emil@explore-rexus.de

<sup>(2)</sup>University of Stuttgart, Thuermchenswall 15, 50668 Cologne, Germany, Christine@explore-rexus.de

<sup>(3)</sup>University of Stuttgart, Buesnauerstr. 30, 70563 Stuttgart, Germany, Andreas@explore-rexus.de

<sup>(4)</sup>Aalen University, Marktplatz 22, 73430 Aalen, Germany, Thorben@explore-rexus.de

<sup>(5)</sup>University of Stuttgart, Hauptstr. 116, 70563 Stuttgart, Germany, Robert@explore-rexus.de

<sup>(6)</sup>University of Stuttgart, Thuermchenswall 15, 50668 Cologne, Germany, Juergen@explore-rexus.de

<sup>(7)</sup>University of Applied Sciences Offenburg, Bergstraße 17a, 77971 Kippenheim, Germany, Daniel@explore-rexus.de

<sup>(8)</sup>University of Stuttgart, 59 Miller Street, Room 814, Glasgow, G1 1EB, United Kingdom, Johannes@explore-rexus.de

## ABSTRACT

This paper gives an overview over the “Rocket and Balloon Experiments for University Students” (REXUS/BEXUS) program, which allows student teams from European universities to participate in and to coordinate a full experiment project from conceptualization until flight and evaluation. Some requirements which should be met by the student teams are mentioned. The features of the program and the opportunities offered to the student teams are highlighted. In the following the REXUS team, EXPLORE is shortly introduced. The experiment outline of EXPLORE together with important lessons learned from the implementation phases, including technical, management, team and outreach aspects are presented. Thereby emphasis is put on the skills which the students did acquire or advance by participating in the REXUS program.

## 1. WHAT IS REXUS/BEXUS?

The “Rocket and Balloon Experiments for University Students” (REXUS/BEXUS) program allows students from universities and other institutions of higher education across Europe to carry out scientific and technological experiments on research rockets and balloons. Each year, two rockets and two balloons are launched, carrying up to 20 experiments designed and built by student teams. The REXUS/BEXUS program is realized under a bilateral agency agreement between the German Aerospace Centre (DLR) and the Swedish National Space Board (SNSB). The Swedish share of the payload has been made available to students from other European countries through collaboration with the European Space Agency (ESA). EuroLaunch, cooperation between the Esrange Space Centre of the Swedish Space Corporation (SSC) and the mobile Rocket Base (MORABA) of DLR, is responsible for the campaign management and operations of the launch vehicles. Experts from ESA, SSC and DLR provide technical support to the student teams throughout the

project. REXUS and BEXUS are launched from Esrange Space Centre in northern Sweden. For more information, visit [1].

## 2. WHAT IS REXUS/BEXUS OFFERING?

REXUS experiments are launched on an unguided, spin-stabilized rocket powered by an Improved Orion motor with 290 kg of solid propellant. It is capable of taking 40 kg of student experiment modules to an altitude of up to 100 km. Flight duration from lift-off to touch down is about 15 minutes including about two to three minutes of microgravity. The vehicle has a length of approx. 5.6 m and a body diameter of 35.6 cm. BEXUS experiments are lifted by a balloon with a volume of 12000 m<sup>3</sup> to a maximum altitude of 35 km, depending on the total experiment mass (40-100 kg). The flight duration is two to five hours [1].



Figure 1. The REXUS rocket and the BEXUS balloon.

A lot of experiments use microgravity, but there are also experiments dealing with deployment of structures, attitude control, re-entry vehicles and materials, landing and recovery, investigation of the atmosphere and magnetosphere, radiation detection, solar weather, communication and navigation systems and even microbiology.

The REXUS/BEXUS projects are geared to the ECSS standards, i.e. the project cycle is precisely determined, starting with the call of proposals followed by the project phases defined in [2]. The experts of EuroLaunch thereby play the role of a customer who commissioned the teams to design and build experiments for the rockets or the balloons respectively.

The status of the teams is continually checked through the student experiment document (SED) [3] and through several reviews. Reviews like the preliminary design review (PDR) or the critical design review (CDR) not only benefit EuroLaunch. On the one hand they are important project milestones for the teams, and on the other hand the teams get important feedback from the experts.

When participating in the REXUS/BEXUS program the students have also the opportunity to visit several ESA and DLR sites like the European Space Research and Technology Centre (ESTEC) in Noordwijk in the Netherlands, the Columbus Control Centre, located at the DLR in Oberpfaffenhofen, as well as the DLR, located in Bremen, which is close to the famous 146 m Drop Tower Bremen. Thus students can not only have a look at facilities of a potential employer but they also get in contact with space professionals.



Figure 2. ESTEC (top left), Columbus Control Centre (top right), DLR Bremen (bottom left), Drop Tower Bremen (bottom middle), DLR Stuttgart (bottom right).

In order to increase this contact and the resulting transfer of knowledge between the professionals and the students, the REXUS/BEXUS program includes a training week. As the rocket and balloon launches, the training week takes place at the Esrange Space Centre near Kiruna in northern Sweden. Unlike the launches, the training week is part of the early phase of the project. It aims on informing the students about all important topics concerning the design and launch of rockets or balloons respectively. These are for instance power supply systems, communication and data transfer systems or just the safety instructions or procedures during the countdown.

As the REXUS/BEXUS program is not arranged as a competition between the teams, communication and transfer of knowledge between the teams is requested and supported by EuroLaunch. Therefore the teams congregate regularly on due dates, like the project reviews, the training week and of course the launch campaign. In this way the project provides the opportunity to gain multinational and also multicultural

experience as well as to socialize with students from other universities throughout Europe.

### 3. WHICH REQUIREMENTS SHOULD A TEAM MEET?

When forming a team it is recommended that students form teams of four to eight people. They should try to include people from different disciplines and ensure that the team has a good range of skills addressing the many different tasks involved [1]. For example a team should include a scientist who defines the parameters of the experiment and interprets the measurements. It should have a mechanical engineer, who designs and builds the structure. The extensiveness of the workload concerning electronics and software is sometimes underestimated. It is crucial to have an electronics engineer to design and manufacture the circuit boards, as well as a software engineer to program the commands and data storage. Last but not least a team should have someone with good communication skills to develop and execute a successful outreach program. Besides, soft skills are also important. A good team spirit is desirable and every team member should be ready to take responsibility.



Figure 3. EXPLORE team spirit.

When participating in the project, the teams have to face a lot of work. Full time students must be aware of the fact that they most likely have to invest a lot of spare time into the project. But, it is also often possible to integrate the project work into the curriculum. Teams should think about facilities and expert knowledge they might need during the project. It is highly requested to have the endorsement of a university department or research institute. Students will probably need to use laboratories and specialized tools and they will almost certainly need advice when unforeseen problems arise.

#### 4. WHO IS THE EXPLORE TEAM?

The experiment was conceptualized by a team of aerospace engineering students from the University of Stuttgart and realized in an extended team with an electrical engineering student from the University of Offenburg and a software engineering student from the University of Aalen. The students are of different age-groups. Some are in their first year at university and since the beginning of the project others have already graduated. The team has been selected by the DLR to fly on the research rocket REXUS 9 in February 2011. To learn more about the EXPLORE team visit [4].



Figure 4. The EXPLORE team.

#### 5. WHAT IS THE EXPLORE EXPERIMENT?

EXPLORE stands for “EXPeriment for Liquid On-orbit REFueling”. It simulates the refueling process under microgravity conditions; in particular the influence of the liquid inflow velocity is investigated to receive a maximum fill level in the tank. In order to do so the movement of the test liquid is recorded during the filling process and analyzed afterwards.

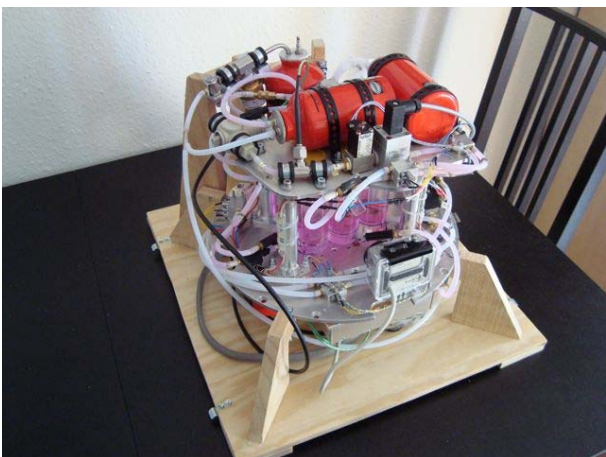

Figure 5. The EXPLORE experiment.

The experiment comprises the refueling system, the control and measurement electronics, and the structural mounting. The overall mass of the experiment is about 13 kg. In realizing the EXPLORE project, the cooperation with non-space-specialized industry to minimize cost and complexity of the hardware is emphasized. Also, it allows accentuating the outreach aspects of the student experiment. To learn more about the EXPLORE experiment and the team visit [5].

#### 6. WHICH SKILLS DID EPXLORE GAIN AND ADVANCE BY PARTICIPATING IN THE REXUS PROJECT?

There is an immense variety of disciplines the EXPLORE team members have to deal with. First and maybe most important issue is the project management. The project frame is given and the students are guided by EuroLaunch but still the management and decision making is done by the students. First of all the experiment’s objectives and requirements have to be defined. Then, the project has to be scheduled and work packages have to be distributed. Throughout the project lifecycle one has to keep an eye on the overall progress, on the budget, on the documentation and the next steps on the schedule. Administrative tasks like these are done by the team manager, who is also the representative contact person of the team. Risk management is another issue of the project planning. Risks concerning all different topics from breakdown of the structure to malfunction of any component or even incapacity of work due to a sick team member have to be defined and assessed. In parallel procedures have to be prepared in order to minimize or even to eliminate these risks. All the project management is done using the MS Office software.

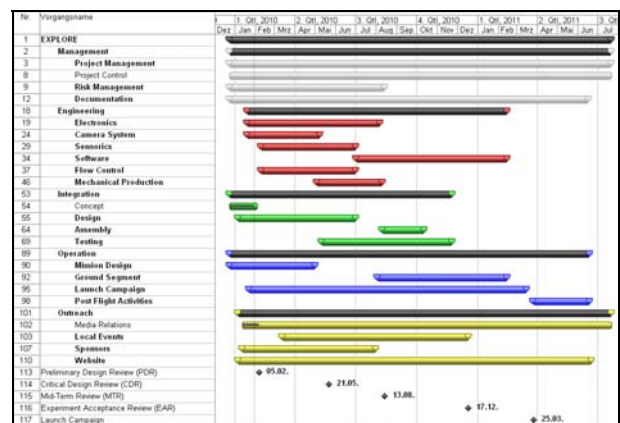
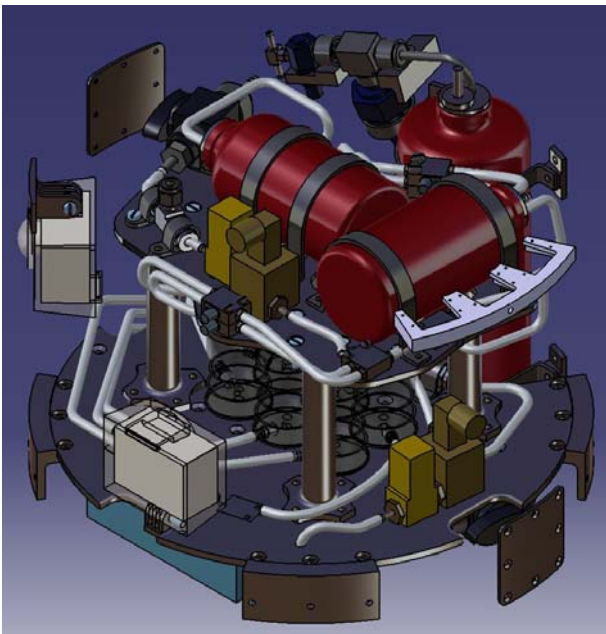

Figure 6. EXPLORE schedule.

Next issue to mention is the engineering part. This is most interesting for most of the team members as it gives the opportunity to apply the theoretical knowledge learned at university. Starting from sketch and defining

the boundary conditions independently are the most exciting tasks for the students, where they meet the challenges, search for solutions, discuss the possibilities and make decisions on their own. Some experiment components are self-designed, some can be bought. Self-designed components, as well as bought components arise on sketch at first, but are assembled using computer aided design programs (CAD) afterwards. The whole experiment is implemented with CAD, as can be seen in Figure 7, and divided into subsystems, which are again divided into several component assembly groups. The system engineering approach is crucial in order to keep track of the complex overall system, which in the end consist of over 98 components and over 430 parts. While assembling with CAD the students also pay attention to design the system in a way that it fits into the REXUS rocket module as well as screws can be reached by screwdrivers. The CAD tool used by the students is CATIA [6].



*Figure 7. EXPLORE is entirely computer aided designed.*

Most of the self-designed components are produced by professionals working in the university's workshops but the rest is made by the students themselves. This is also very valuable because the students have hardly the possibility to get hands-on experience at university. A lot of work also concerns the bought components, for example in terms of funding and testing. The students have to search for manufacturers offering components which meet the requirements. EXPLORE for example needs containers for pressurized air and water. Different ones made out of aluminum or carbon fiber reinforced plastics are available. The team decides to choose

aluminum fuel bottles made by Primus [7]. Due to the fact that EXPLORE proposes to participate in the manufacturer's publicity campaign called "Primus was here" by sending the fuel bottles to the edge of space on board the REXUS rocket, Primus provides several bottles for free. Similar sponsoring was provided for the cameras, which were used to record the EXPLORE experiment itself, as well as recording the rocket flight. In exchange of a high definition video material of the rocket flight the Cam-For-Pro Company provides several helmet cameras for free [8]. Although the EXPLORE team could generate enough funding to purchase most experiment components themselves, DLR also provides component ordering and funding. Not only experiment related requirements but also requirements concerning the whole rocket have to be met. In order to proof the suitability of their components to EuroLaunch, the students have to either show official certificates of bought components or test them themselves. Before testing them themselves, they have to develop well-thought-out test procedures. To do all that, the students have to learn how to handle and how to commission the components which have been ordered and delivered. Afterwards they have to test the components both as a single part and after they have been assembled into the subsystem. Mainly in the early phase of the project, when concepts have to be evaluated, the team applies the trial-and-error method. For example this is how the water reservoirs are tested, as can be seen in Figure 8. The water is stored in an ordinary party balloon which is inside a Primus fuel bottle. The water is pushed out by pressurizing the air which surrounds the party balloon inside the fuel bottle.



*Figure 8. EXPLORE is testing the Primus fuel bottles.*

In addition to the component tests, the entire experiment has to pass some load tests. The first one was the thermal-vacuum test, which was performed at the Institute of Space Systems of the University of Stuttgart. The REXUS User Manual requires a test in a vacuum chamber at a pressure of 0.5 mbar and tests at  $-10^{\circ}\text{C}$

and +45° C [3]. Temperatures below 0° C are critical to the EXPLORE experiment as the water has to be liquid. As the water is mixed with an anti-freeze agent, the experiment passes the test confidently. The next important system test is the shaker test. The fully integrated experiment module has to pass the test in order to verify that the assembly will endure the REXUS launch without suffering any critical damage which could negatively affect the experiment itself or any other part of the REXUS vehicle [3]. The shaker test was performed at the DLR site in Stuttgart. The third test entirely focuses on software and electronics. The REXUS User Manual requires the test of the compatibility of the EXPLORE Experiment with the REXUS Service System. To perform this test DLR built a Service System Simulator to simulate the behavior of the REXUS Service System. During the test the EXPLORE experiment is connected to the Service System Simulator and a complete run of the experiment has to be performed [3]. This test is performed at the DLR site in Oberpfaffenhofen near Munich. Some impressions of the system tests can be seen in Figure 9.

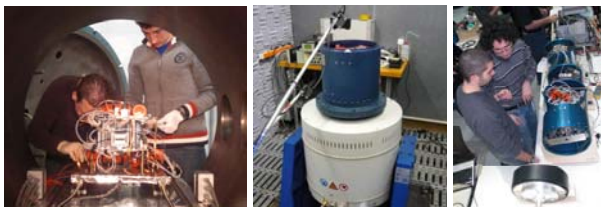

Figure 9. Vacuum chamber (left), shaker (middle), service system simulator (right).

The electrical engineering and software engineering part is new for most of the students. After the setup of the electrical components is fixed, one can start to design the circuit board. Students can learn a lot about power supply, how to integrate and how to trigger microcontrollers or how to assure electromagnetic compatibility. As with the mechanical components the electrical parts have to be tested as a single part as well as being part of the whole circuit board. In order to do all that, the students have to be able to solder. Thus a soldering advanced training at the DLR location in Oberpfaffenhofen is part of the REXUS/BEXUS program. For the design of the circuit board the team uses the software tool Eagle [8]. EXPLORE implements three different programs. The most important one is programmed into the controller, which has to assure that the experiment is running autonomously during the rocket flight. For programming the microcontroller the team uses the computer language C and the software tool AVR Studio [10]. The second program is the ground support software, which can be seen in Figure 10. It is executed in the rocket control centre during flight in order to display the housekeeping data of the experiment. To program the ground support software

the computer language C++ and the software tool QT [11] is used. The third program is implemented by using Lab View [12]. It is executed to sort and to graph the data which is saved into the log files.

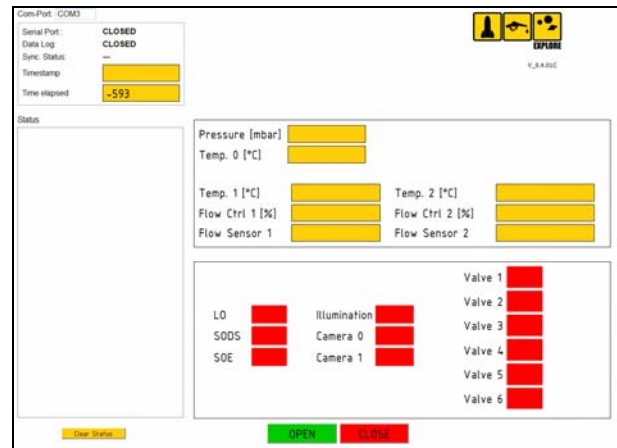

Figure 10. EXPLORE Ground Support Software.

Outreach is another important issue the students have to deal with. The term outreach enfolds every actions which aims on getting the public aware of the EXPLORE team and the REXUS/BEXUS program. The first action usually is to set up the internet presence, like a team homepage, Facebook or Twitter. The students use TYPO3 [13], a free and open source content management system, to set up and to service the team homepage. In addition the team creates posters, flyers and stickers. The layouts are designed with CorelDRAW Graphics Suite [14]. The printed media are for example used for public events like the Yuri's Night in Stuttgart, the World Space Party on April 11, 2010 [15]. Some impressions of the Yuri's Night in Stuttgart can be seen in Figure 11.



Figure 11. First REXUS public day in Stuttgart.

Embedded in the larger event format, EXPLORE and REMOS organized the 1<sup>st</sup> REXUS Public Day, inviting

all other current REXUS 9/10 teams as well as past REXUS 7/8 teams to come to Stuttgart and to showcase their work with posters, presentation, handout material, exhibition hardware, and hands-on activities. A total of four teams (EXPLORE, REMOS from Stuttgart, SQUID from Stockholm, FOCUS from Munich) were present in Stuttgart and contributed to a very successful event with more than 500 visitors and diverse offerings for the mixed audience [3]. Besides the team presents the REXUS/BEXUS program and the EXPLORE experiment to an audience of the Institute of Space Systems of the University of Stuttgart and to an audience of the University of Aalen. The presentations are prepared using PowerPoint.

The students improve their presentation skills and media skills by participating to a seminar which is offered by ESA professionals as part of the REXUS/BEXUS project, and by getting in contact with media like the press or even television camera crews.

Through participating in the project and the interdisciplinary cooperation between mechanical, electrical and software engineering in a team, the students advance many soft skills. The most important ones to mention are the ability to work in a team, to take responsibility, to communicate and to give presentations. Furthermore, as documentation and presentation is done in English, the student train and improve their English skills.



*Figure 12. EXPLORE at the critical design review presentation.*

## **7. WHICH LESSONS WERE LEARNED BY THE EXPLORE TEAM?**

This chapter delivers an insight into some important experiences the students gained while working on the project. Students could avoid a lot of lost time and work if keeping these lessons learned in mind.

The majority of problems are based on a lack of communication and information as well as misunderstandings. Thus it is absolutely crucial to very

precisely minute and document everything. Not only changes in the design, but also the reasons which lead to the changes have to be documented.

There is an infinite amount of solutions for any problem but brainstorming has to come to an end at some point. Now one of the solutions has to be chosen and put into action. In the following one has to keep in mind that the chosen solutions may turn out to be unfeasible. This leads to unforeseen changes which usually infect the overall design. In order to minimize these risks one should consult experts or better have them as team members.

The majority of work begins where theoretical knowledge learned at university ends, after the preliminary design is done. When it comes to providing components, it is most important to keep in mind that the delivery time can reach up to months. When it turns out that a delivered component is damaged or it does not meet the requirement at all, it has to be replaced. Thus all components have to be tested quickly after they have been delivered. In addition spare parts have to be scheduled.

The amount of work concerning the electronics and the software was underestimated. These tasks should be processed as soon as possible. The design of a circuit board as well as programming a microcontroller is not easily done without precognition. Figure 13 gives an impression of the complexity of the EXPLORE circuit board. The team should include an expert who can concentrate on this task.

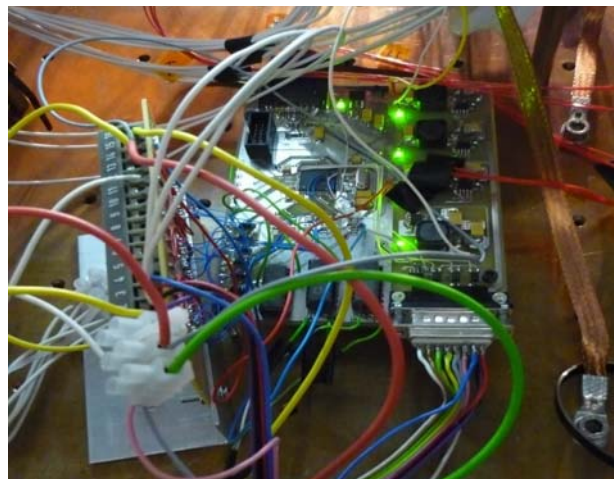

*Figure 13. EXPLORE circuit board, a problem child.*

Besides it is desirable to have a teammate who concentrates on the software. The teammates working on electronics and software have to communicate well and they have to know all the important interfaces between electronics and software. When handling the electronics one has to be extremely careful in order to avoid short circuits or electrostatic discharges. Experts from EuroLaunch are telling this several times during

the training week and during the launch campaign. One should always remember the warnings and work on electronics calm and concentrated.

Debugging a circuit board which suffered several electrostatic discharges is almost impossible, but also debugging a program written in a higher computer language is time-killing work. A stable and good working program which meets all requirements should not be changed or upgraded. Never change a running system.

## 8. CONCLUSION

The REXUS/BEXUS project is an excellent opportunity for students to get hands-on experience which can hardly be gained at universities. It offers a multitude of opportunities for experimental scientific research concerning topics like microgravity or atmospheric research. Students may experience the full project lifecycle of their experiment, from design and development over building and testing up to operation and data analysis. They gain an insight in facilities of several European space agencies. They are guided by space professionals who have many operating experience. By participating, students advance soft skills like the ability to work in a team, to take responsibility, to communicate and to give presentations. Furthermore they train and improve their English skills. The EXPLORE team is proud and appreciative to participate in the REXUS project. The team wants to encourage students throughout Europe to take the chance to experience a real space project.

## 9. ACKNOWLEDGEMENTS

The EXPLORE team was constantly supported for the experiment realization, including technical and management expertise, hardware provisions and financial support. Therefore the EXPLORE team would like to acknowledge special support by:

- The Ministry of Economics (BMW) through the German Aerospace Center (DLR). DLR was maintaining overall REXUS project management and supported the acquisition of hardware.
- The Institute of Space System (IRS) of the University of Stuttgart. Represented by its director Prof. H.-P. Roeser, the IRS provided access to local expertise and facilities as well as logistics support for EXPLORE.
- Prof. S. Schleichtriem, lecturer at IRS and head of DLR Lampoldshausen, and his research staff provided technical advice in the area of refueling and propulsion. They also provided initial test material for the fluid system to us, particularly tubing and fittings.
- The Institute of Aerospace Thermodynamics (ITLR) of the University of Stuttgart. The in-house mechanical workshop of the institute

manufactured most of the customized EXPLORE components.

- Development and management of the EXPLORE website was supported by IT-Services Benjamin Ackermann in order to provide a flexible and powerful platform for outreach and communication.
- Primus AB of Stockholm, Sweden, supported the EXPLORE team with their expertise in fuel handling and provides gas and fluid tanks as well as manufacturing of components (tank caps and connectors) for the fluid system.
- The foundation of the federal state bank of Baden-Wuerttemberg (Landesbank Baden-Wuerttemberg, LBBW) supported EXPLORE financially with a substantial amount to procure components, raw material and test equipment.
- The Evonik business segment Acrylic Polymers is manufacturer of PLEXIGLAS® and offered special discount support for the EXPLORE raw material to build our test chambers.
- The German Ralf Bohle GmbH is market leader for bicycle tires in Europe with its Schwalbe label. Schwalbe valves were used to fill and pressurize the EXPLORE gas section.
- B.I.O-TECH e.K. supported EXPLORE as specialist for fluid sensorics. They provided miniature mass flow meters to monitor the exact propellant flow rate during the rocket flight.
- The Walther-Blohm-Stiftung supported EXPLORE financially for the procurement of experiment hardware and electronics as well as for the covering of general team costs due to outreach activities and travel costs.
- GoPro-Shop.com supported EXPLORE as an official distributor of GoPro HD camera products in Germany. They provided GoPro HD Hero helmet cameras for high quality video coverage of the experiment and flight.
- Staiger fluid systems supported EXPLORE by the provision of special discounts in the procurement of miniature fluid valves and by provision of additional mounting support elements and expertise.
- Hydrobar Hydraulik und Pneumatik GmbH of Boeblingen/Sindelfingen was supporting the EXPLORE experiment with their extensive fluid system expertise and by providing tubing hardware to the team.
- New Pig of Hazeldonk, the Netherlands, is an expert in absorption products and provided absorption pads to EXPLORE as fluid collection devices.
- The Studentenwerk Stuttgart e.V. is a local organization to support and to enable student projects at the University of Stuttgart and abroad. The Studentenwerk confirmed financial support

to the team for hardware procurement and travel expenses.

- Financial support was also provided by the Erich-Becker-Stiftung to cover travel costs for several meetings abroad.

EXPLORE also thanks our friends Leonore Kleinkauf, Bernd Bilian and Michael Schnurr. Special thanks go also to the REXUS/BEXUS supervisors: Andreas Stamminger and Mark Fittock, as well as Olle Persson (SNSB).

## 10. REFERENCES

1. Rocket and Balloon Experiments for University Students: <http://www.rexusbexus.net/> (visited 2009/10/30)
2. European Cooperation For Space Standardization, ECSS-E-ST-10C: *Space Engineering, System engineering general requirements*
3. EXPLORE Student Experiment Documentation *RX09-EXPLORE\_SED-v4\_1-08February11*
4. The EXPLORE team: <http://www.explore-rexus.de/> (visited 2010/11/03)
5. 20th ESA Symposium on European Rocket and Balloon Programs and Related Research, A-119: *EXPLORE: technology and process demonstration for orbital refueling on a sounding rocket*
6. Dassault Systems: <http://www.3ds.com/> (visited 2011/05/15)
7. Primus: <http://www.primus.se/> (visited 2011/05/15)
8. Cam For Pro, GoPro authorized dealer: <http://www.camforpro.com/> (visited 2011/05/15)
9. CadSoft Computer GmbH: <http://www.cadsoft.de/> (visited 2011/05/15)
10. Atmel Corporation: <http://www.atmel.com/> (visited 2011/05/15)
11. QT, owned by Nokia: <http://qt.nokia.com/> (visited 2011/05/15)
12. National Instruments: <http://www.ni.com/> (visited 2011/05/15)
13. TYPO3 Association: <http://www.typo3.com/> (visited 2011/05/15)
14. Corel Corporation: <http://www.corel.com/> (visited 2011/05/15)
15. Yuri's Night: <http://www.yurisnight.de/> (visited 2010/03/05)